

# LTECH

## DMX512 DECODER LT-905-OLED

**5**  
CHANNELS

OLED display  
8 bit / 16 bit  
2 kinds of DMX interfaces  
Dimming curve: 0.1-9.9  
Short circuit/Over current/Over-heat protection



Photoelectric  
isolation



[www.ltech-led.com](http://www.ltech-led.com)

[www.ltech-led.com](http://www.ltech-led.com)

# LTECH

## Product introduction:

1. Designed with 5 channels output, and Max. 5A per channel, up to 600W output.
2. Easy operation with OLED display and the touch buttons.
3. 5 modes optional: dimming, CT, RGB, RGBW, RGBYW.
4. 5-pin XLR, RJ45 DMX interface with photoelectric isolation.
5. With RDM remote management protocol, the operations can be completed via the RDM editor, such as parameters browsing & setting, DMX address setting, equipment recognition, etc.
6. With firmware upgrade function.
7. With short circuit, over current and over-heat protection, as well as warning function when fault.
8. With power-on state management and fast self-testing function.
9. 16bit (65536 levels) / 8bit (256 levels) grey level optional.
10. Optional for standard, liner, LOG or custom 0.1-9.9 dimming curve

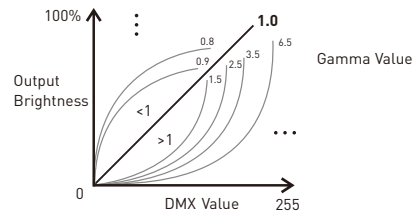

5-pin XLR



RJ45



RDM



Photoelectric  
isolation



Short circuit  
protection



Over current  
protection



Over-heat  
protection



Display

## Technical specs:

Model:	LT-905-OLED	Photoelectric isolation:	Yes
Input signal:	DMX512/RDM	Working temp.:	-30°C~65°C
Input voltage:	12~24Vdc	Dimensions:	L122×W110×H37mm
Current load:	5A × 5CH Max. 25A	Package size:	L127×W123×H41mm
Output power:	(0~60W...120W) × 5CH Max. 600W	Weight (G.W.):	550g
DMX interface:	5-pin XLR, RJ45		
Control mode:	Dimming/CT/RGB/RGBW/RGBWY		
Dimming curve:	0,1~9,9		
Grey level:	8bit (256 levels) /16bit (65536 levels)		
Protection:	Short circuit / Over current / Over-heat		

## Product size:

Unit: mm

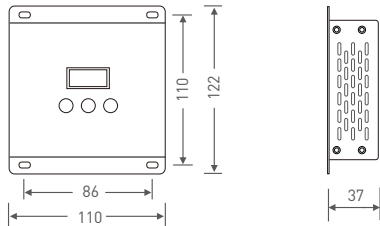

FC CE RoHS

warranty  
5 years



## Main component description:

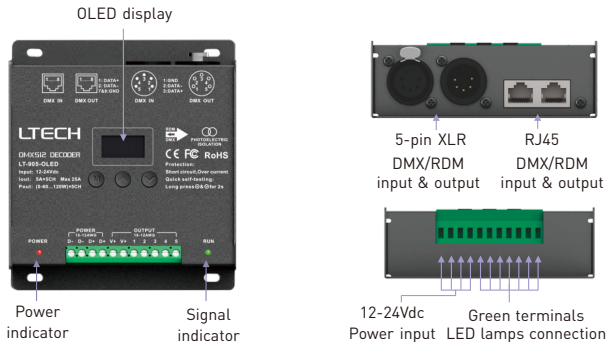

## OLED display interface:



Press "M" key, switch entries.  
Press "^" or "v" key, parameter adjustment.  
Long press "M" key, back to main page.  
Exit: back to previous page.

1. DMX address setting

DMX: 001 Hz: High  
Mode: RGB 8bit  
Curve: Standard  
Dim: Smo TOOL&v

Main page

Press "^" or "v" key to set DMX address.  
Range: 001-512

## 2. PWM frequency

DMX: 001 Hz: **High**  
 Mode: RGB 8bit  
 Curve: Standard  
 Dim: Smo TOOL&v

Press "∧" or "∨" key to choose.

Optional :

**Std (standard)**

High

Mid (middle)

Low

No flicker in video camera.

Smooth and delicate, human eye is comfortable. \* It is recommended to use standard.

## 3. Mode

DMX: 001 Hz: High  
 Mode: **RGB** 8bit  
 Curve: Standard  
 Dim: Smo TOOL&v

Press "∧" or "∨" key to choose.

Optional: Dim / CT / RGB / RGBW / RGBWY

## 4. Grey scale

DMX: 001 Hz: High  
 Mode: RGB **8bit**  
 Curve: Standard  
 Dim: Smo TOOL&v

Press "∧" or "∨" key to choose.

Optional : 8bit

16bit (choose it if the master controller support this function)

## 5. Dimming curve

DMX: 001 Hz: High  
 Mode: RGB 8bit  
 Curve: **Standard**  
 Dim: Smo TOOL&v

Press "∧" or "∨" key to choose.

Optional : **Standard**

Linear

0.1-9.9

It is recommended to use standard, 0.1-9.9 is for special requirements.

## 6. Enhance dimming

DMX: 001 Hz: High  
 Mode: RGB 8bit  
 Curve: Standard  
 Dim: **Smo** TOOL&v

Press "∧" or "∨" key to choose.

Optional : **Std (standard)**

Smo (smooth)

\* It is recommended to use standard.

Smo: This option with smooth processing, realize the dimming flicker-free and dynamic effects more downy.

## 7. Tool

DMX: 001 Hz: High  
 Mode: RGBW 8bit  
 Curve: Standard  
 Dim: Smo **TOOL&v**

Press "∧" or "∨" key to enter submenu

Screen: ON+Addr  
 Contrast: 40%  
 Beep: ON TEST&v  
 EXIT&v

Test

Press "∧" or "∨" key to enter submenu of test.

**001**

Screen: ON+Addr

Screensaver open and display address if undo for 2 minutes.

**000**

Screen: ON+black

Screensaver open and black if undo for 2 minutes.

DMX: 001 Hz: High  
 Mode: RGBW 8bit  
 Curve: Standard  
 Dim: Smo TOOL&v

Screen: OFF

Screensaver not enable.

CH1: 255 CH2: 255  
 CH3: 255 CH4: 255  
 CH5: 255 ALL: 255  
 EXIT &V

Brightness setting (range: 0~255)

Press "∨" to exit

\* Fast self-testing function: press "∧" or "∨" keys simultaneously for 2-3 seconds under any page, decoder will enter self-testing function.

## Wiring diagram:

### 1 Connecting LED lights:

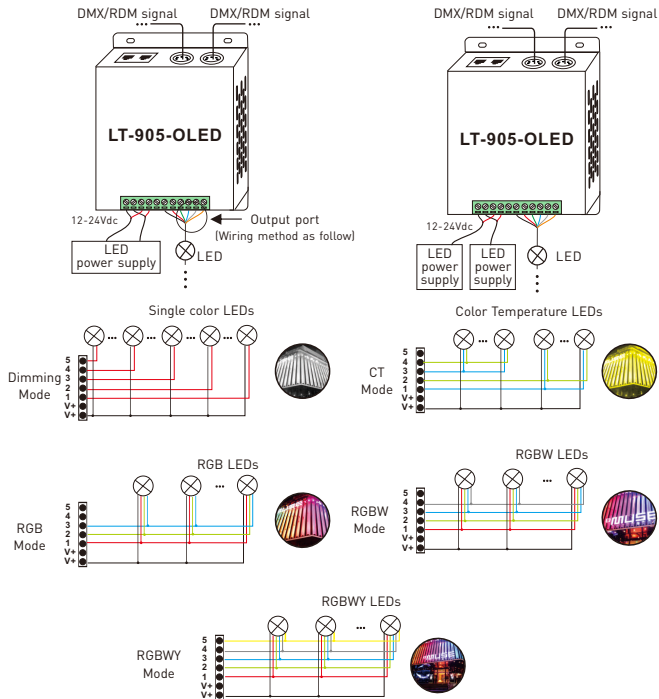

### 2. DMX console connection:

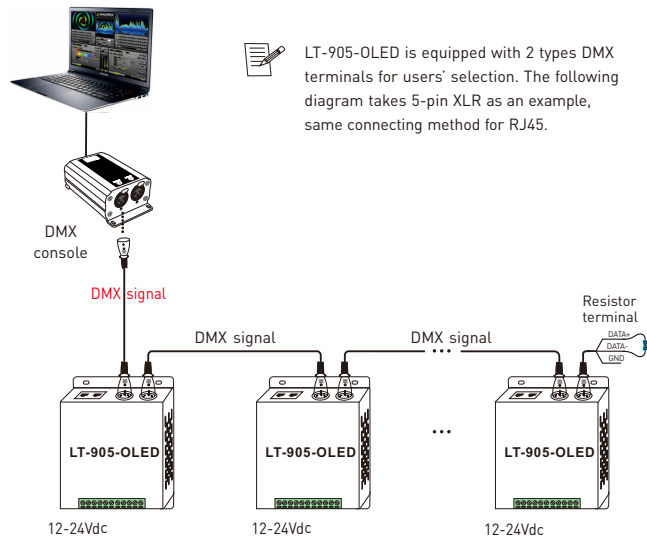

- \* An amplifier is needed if more than 32 decoders are connected or use overlong signal line, signal amplification should not be more than 5 times continuously.
- \* If the recoil effect occurs because of longer signal line or bad line quality, please try to connect 0.25W 90-120Ω terminal resistor at the end of each line.

## 3. The connection diagram of 2 kinds of DMX/RDM terminals:

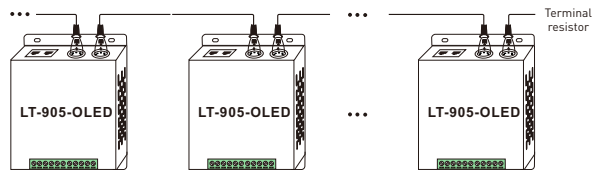

5-pin XLR connected in parallel

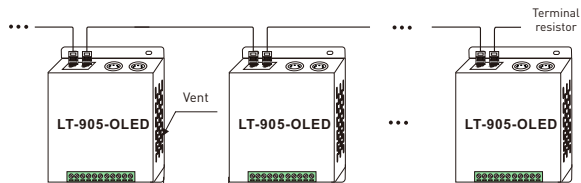

Installation distance &gt; 20mm

RJ45 connected in parallel

These 2 terminals can be connected in a mixed way.

\* **Installation Attention** : please reserve enough ventilation distance between decoders (>20mm), be sure not to block the vent, or will affect lifetime of decoder for poor heat dissipation.

## Address setting table

Mode	DIM	CT	RGB	RGBW	RGBWY	
Address Quantity	1	2	3	4	5	
Resolution	8bit	8bit	8bit	8bit	8bit	
Channel	1	001	001	001	001	001
	2	001	002	002	002	002
	3	001	001	003	003	003
	4	001	002	003	004	004
	5	001	002	003	004	005

Mode	DIM	CT	RGB	RGBW	RGBWY	
Address Quantity	2	4	6	8	10	
Resolution	16bit	16bit	16bit	16bit	16bit	
Channel	1	001 002	001 002	001 002	001 002	001 002
	2	001 002	003 004	003 004	003 004	003 004
	3	001 002	001 002	005 006	005 006	005 006
	4	001 002	003 004	005 006	007 008	007 008
	5	001 002	003 004	005 006	007 008	009 010

## Work with RDM editor

LT-905-OLED can work with LTECH RDM editor (Model: WiFi-RDM01) to realize changing the parameters by long-range setting, wiring diagram as below:

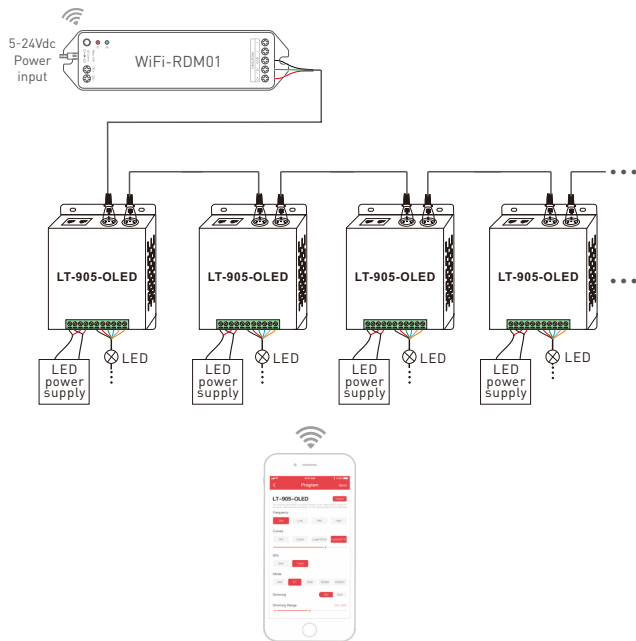

## RDM editor App interface instruction

Download the App, setting the LT-905-OLED parameters (frequency, bit, curve, modes, dimming range, screensaver, etc.) after well connecting the RDM editor, more details, please check the manual of WiFi-RDM01.

Well installation of products first, then working with WiFi -RDM01 to realize setting parameters and firmware upgrade by App.

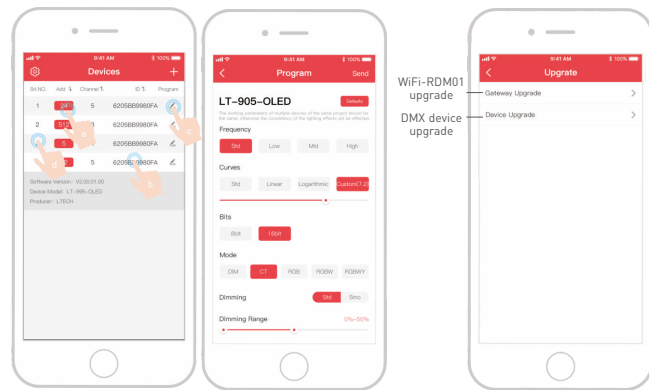

WiFi-RDM01 upgrade  
DMX device upgrade

- click "Add", edited the address in corresponding box.
- Click "ID", get more product details.
- Click "⚙️", enter edited interface
- Click "No.", issue the recognizing command.

Supporting WiFi-RDM01 upgrade and DMX driver upgrade.